

Released Form

Student Name: _____

Spring 2013
North Carolina
Measures of Student Learning:
NC's Common Exams
Common Core Math II



Student Booklet



Public Schools of North Carolina
State Board of Education
Department of Public Instruction
Raleigh, North Carolina 27699-6314

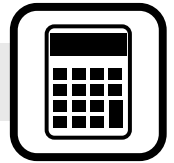

- 1 The equation $s = 2\sqrt{5x}$ can be used to estimate the speed, s , of a car in miles per hour, given the length in feet, x , of the tire marks it leaves on the ground. A car traveling 90 miles per hour came to a sudden stop. According to the equation, how long would the tire marks be for this car?
- A 355 feet
B 380 feet
C 405 feet
D 430 feet

- 2 The heights of two different projectiles after they are launched are modeled by $f(x)$ and $g(x)$. The function $f(x)$ is defined as $f(x) = -16x^2 + 42x + 12$. The table contains the values for the quadratic function g .

x	$g(x)$
0	9
1	33
2	25

What is the **approximate** difference in the maximum heights achieved by the two projectiles?

- A 0.2 feet
B 3.0 feet
C 5.4 feet
D 5.6 feet

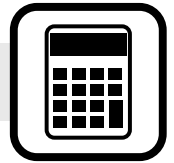

- 3 A city map is placed on a coordinate grid. The post office is located at the point $P(5, 35)$, the library is located at the point $L(15, 10)$, and the fire station is located at the point $F(9, 25)$. What is the ratio of the length of \overline{PF} to the length of \overline{LF} ?
- A 2 : 3
B 3 : 2
C 2 : 5
D 3 : 5
- 4 Twenty-one students at a school have an allergy to peanuts, shellfish, or both.
- Fourteen students at the school are allergic to peanuts.
 - Twelve students at the school are allergic to shellfish.
- How many of the students are allergic to both peanuts and shellfish?
- A 12
B 7
C 5
D 2
- 5 Events M and N have probabilities such that $P(M) = 0.4$, $P(N) = 0.28$, $P(M \cup N) = 0.56$, and $P(M \cap N) = 0.12$. Are event M and event N independent?
- A no, because $P(M) - P(N) = P(M \cap N)$
B no, because $P(M) \cdot P(N) \neq P(M \cap N)$
C yes, because $P(M) + P(N) = P(M \cup N)$
D yes, because $P(M) \cdot P(N) \neq P(M \cup N)$



6 Which expression is equivalent to $(3x^5 + 17x^3 - 1) + (-2x^5 - 6)$?

A $x^5 + 17x^3 - 7$

B $x^5 - 11x^3 - 1$

C $5x^5 + 17x^3 + 7$

D $-6x^5 + 17x^3 + 6$

RELEASED

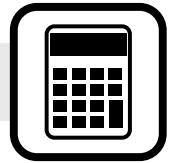

7 Which graph displays the function $f(x)=(2x + 3)(x - 2)$?

A

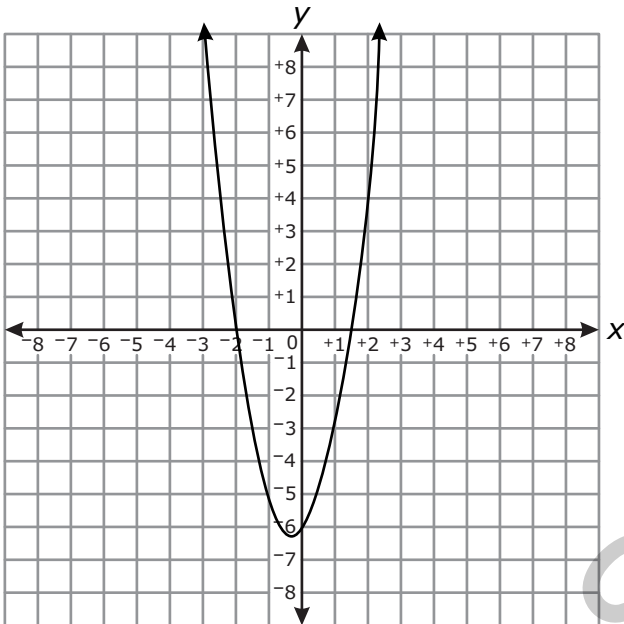

B

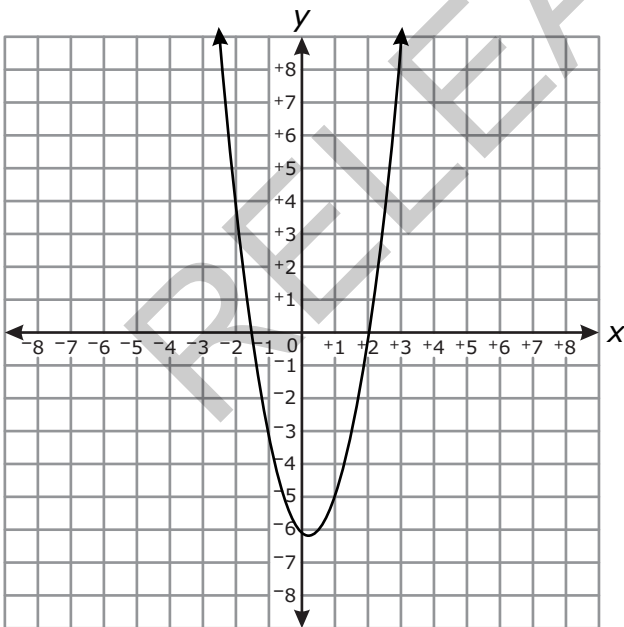

Answer choices C and D are on the following page.

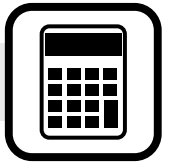

C

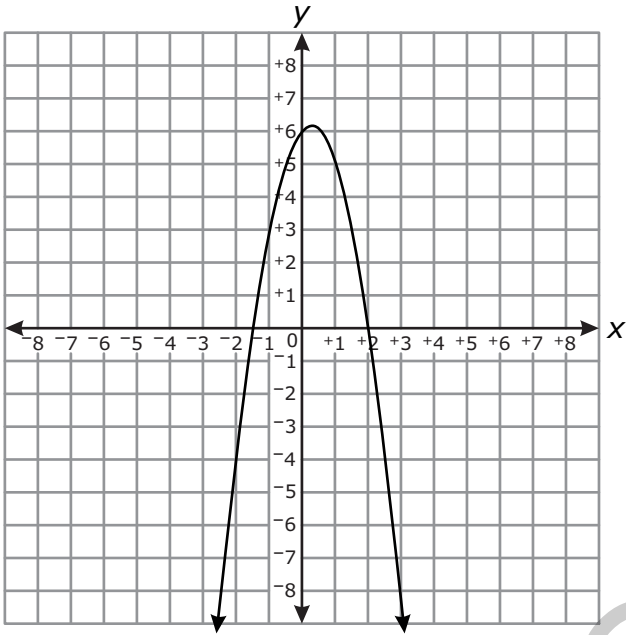

D

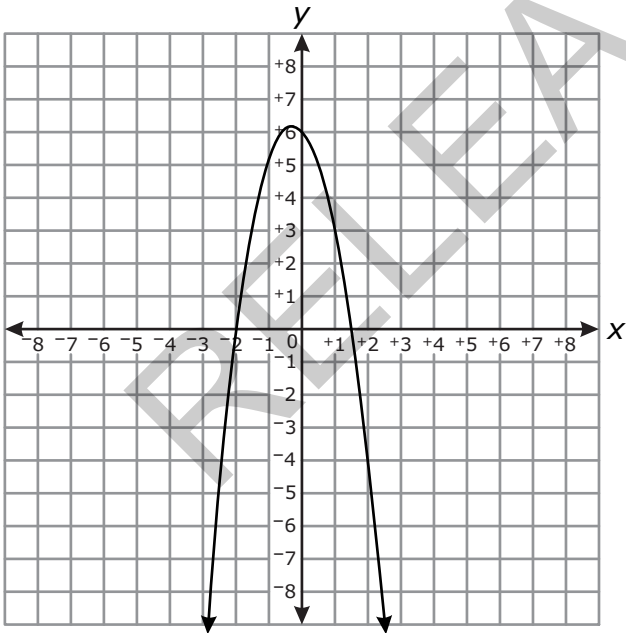

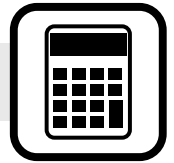

- 8 The sum of two numbers is 24. The sum of the squares of the two numbers is 306. What is the product of the two numbers?
- A 119
B 128
C 135
D 144
- 9 Which equation has exactly one real solution?
- A $4x^2 - 12x - 9 = 0$
B $4x^2 + 12x + 9 = 0$
C $4x^2 - 6x - 9 = 0$
D $4x^2 + 6x + 9 = 0$
- 10 A circular pond is modeled by the equation $x^2 + y^2 = 225$. A bridge over the pond is modeled by a segment of the equation $x - 7y = -75$. What are the coordinates of the points where the bridge meets the edge of the pond?
- A (9, 12) and (-12, 9)
B (9, 12) and (12, 9)
C (9, -12) and (-12, -9)
D (-9, 12) and (12, -9)

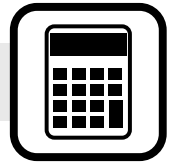

- 11 The volume, V , of a certain gas varies inversely with the amount of pressure, P , placed on it. The volume of this gas is 175 cm^3 when 3.2 kg/cm^2 of pressure is placed on it. What amount of pressure must be placed on 400 cm^3 of this gas?
- A 1.31 kg/cm^2
B 1.40 kg/cm^2
C 2.86 kg/cm^2
D 7.31 kg/cm^2
- 12 A company manufactures DVDs.
- The company spent \$247,000 to develop its process for manufacturing the DVDs.
 - The company spends an additional \$1.25 to manufacture each DVD.

Which function represents the average total cost per DVD, y , for the company to manufacture x total DVDs?

- A $y = \frac{x}{1.25x}$
B $y = \frac{1.25x}{x}$
C $y = \frac{x}{1.25x + 247,000}$
D $y = \frac{1.25x + 247,000}{x}$

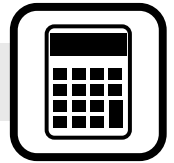

- 13 For a carnival game, a jar contains 20 blue marbles and 80 red marbles.
- Children take turns randomly selecting a marble from the jar.
 - If a blue marble is chosen, the child wins a prize.
 - After each turn, the marble is replaced.
 - Casey has drawn six red marbles in a row.

Which statement is true?

- A If Casey selects another red marble, then 2 of her next 3 picks will be blue marbles because 2 blue marbles are selected for every 8 red marbles selected.
- B The probability that Casey selects a blue marble on the next turn is higher than it was on her last turn because she has chosen so many red marbles in a row.
- C The probability that Casey selects a blue marble on her next turn is the same as it was on the last turn because selections are independent of each other.
- D If Casey draws 4 more times, she will select 2 blue marbles because the probability that a blue marble will be selected is 2 out of every 10 turns.
- 14 A plane intersects a regular triangular pyramid. The plane is parallel to one of the faces of the pyramid. What type of polygon is formed at the intersection?
- A square
- B right triangle
- C isosceles trapezoid
- D isosceles triangle

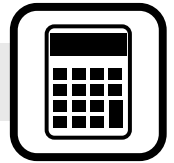

- 15 The number of bacteria in a culture can be modeled by the function $N(t) = 28t^2 - 30t + 160$, where t is the temperature, in degrees Celsius, the culture is being kept. A scientist wants to have fewer than 200 bacteria in a culture in order to test a medicine effectively. What is the **approximate** domain of temperatures that will keep the number of bacteria under 200?
- A $-1.01^\circ\text{C} < t < 2.03^\circ\text{C}$
- B $-0.90^\circ\text{C} < t < 1.97^\circ\text{C}$
- C $-0.86^\circ\text{C} < t < 1.93^\circ\text{C}$
- D $-0.77^\circ\text{C} < t < 1.85^\circ\text{C}$

RELEASED

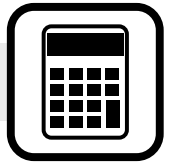

16 Which function is graphed below?

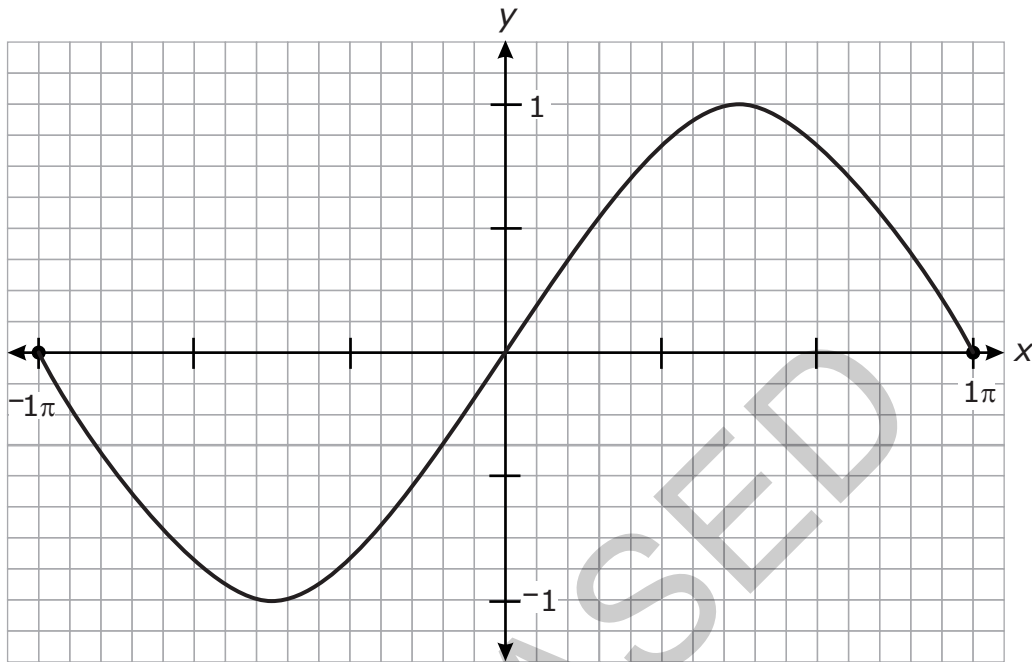

- A $y = \sin x$
- B $y = \cos x$
- C $y = \tan x$
- D $y = \cot x$

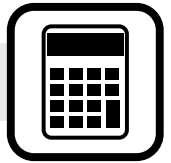

- 17 Which transformation will carry the rectangle shown below onto itself?

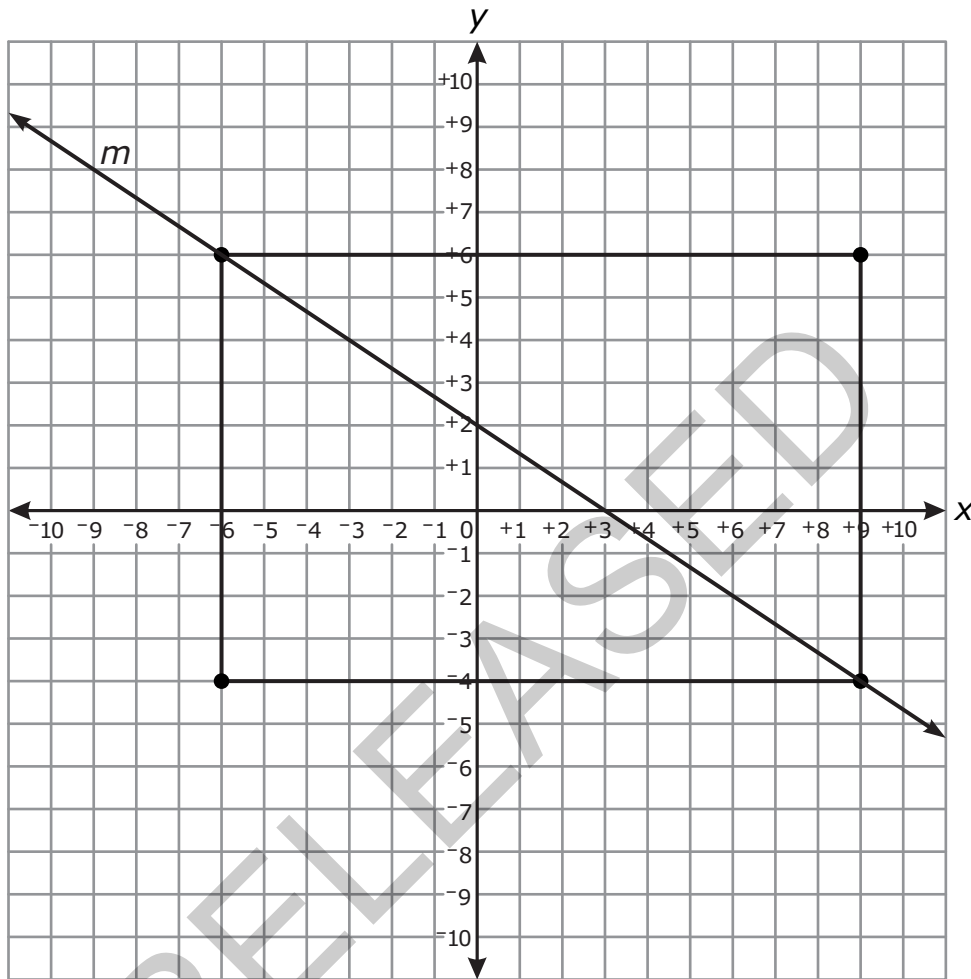

- A a reflection over line m
- B a reflection over the line $y = 1$
- C a rotation 90° counterclockwise about the origin
- D a rotation 270° counterclockwise about the origin

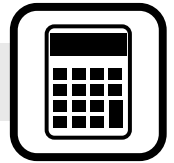

- 18 Which statement must be true about the triangle below?

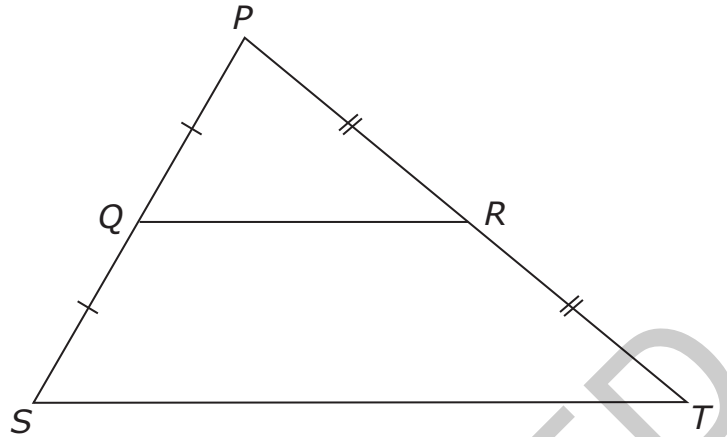

- A $PQ + QS = PR + RT$
- B $\triangle PQR \cong \triangle PST$
- C $ST = 2 \cdot QR$
- D $\angle S \cong \angle T$
- 19 The graph of $f(x) = x^2$ will be translated 5 units up and 2 units to the right. Which function describes the graph produced by the translation?
- A $g(x) = x^2 - 4x + 9$
- B $g(x) = x^2 + 4x - 1$
- C $g(x) = x^2 - 10x + 27$
- D $g(x) = x^2 + 10x + 23$

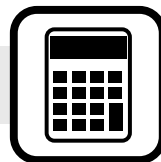

- 20 An investment has a balance of \$2,000 and earns 3.2% interest each year. If \$150 is added at the end of each year by the account holder and no money is withdrawn from the investment, which represents a function that can be used to calculate the investment balance for successive years?

- A $B_n = 0.032B_{n-1} + 2,000, B_0 = 150$
B $B_n = 0.032B_{n-1} + 150, B_0 = 2,000$
C $B_n = 1.032B_{n-1} + 2,000, B_0 = 150$
D $B_n = 1.032B_{n-1} + 150, B_0 = 2,000$

- 21 What is the **approximate** length of \overline{HJ} in the diagram below?

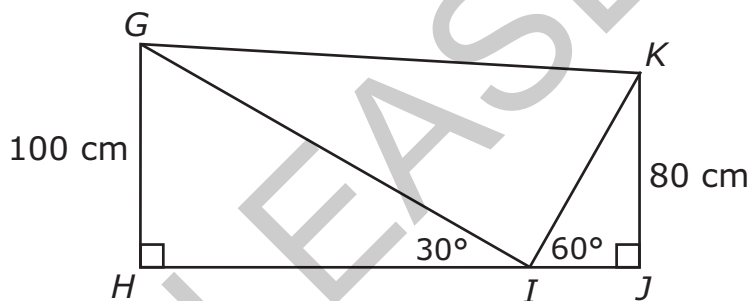

- A 292 cm
B 265 cm
C 219 cm
D 196 cm

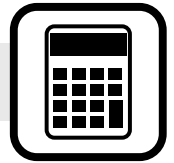

- 22 Angles F and G are complementary angles.
- As the measure of angle F varies from a value of x to a value of y , $\sin(F)$ increases by 0.2.

How does $\cos(G)$ change as F varies from x to y ?

- A It increases by a greater amount.
- B It increases by the same amount.
- C It increases by a lesser amount.
- D It does not change.
- 23 If t is an unknown constant, which binomial must be a factor of $7m^2 + 14m - tm - 2t$?
- A $7m + t$
- B $m - t$
- C $m + 2$
- D $m - 2$
- 24 The value, V , of a car can be modeled by the function $V(t) = 13,000(0.82)^t$, where t is the number of years since the car was purchased. To the nearest tenth of a percent, what is the monthly rate of depreciation?
- A 1.5%
- B 1.6%
- C 9.2%
- D 18.0%



25 Which expression is equivalent to $\left(\frac{16x^{\frac{1}{6}}y^{-2}}{x^{-\frac{1}{6}}y^6}\right)^{\frac{3}{2}}$?

A $24x^{\frac{9}{2}}y^{\frac{9}{2}}$

B $\frac{24x^{\frac{3}{4}}}{y^9}$

C $\frac{64}{x^{\frac{1}{2}}y^8}$

D $\frac{64x^{\frac{1}{2}}}{y^{12}}$

This is the end of the multiple-choice portion of the test.

RELEASED

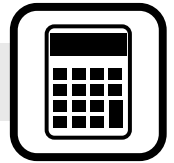

The questions you read next will require you to answer in writing.

1. Write your answers on separate paper.
2. Be sure to write your name on each page.

- 1 In the figure below, a pole has two wires attached to it, one on each side, forming two right triangles.

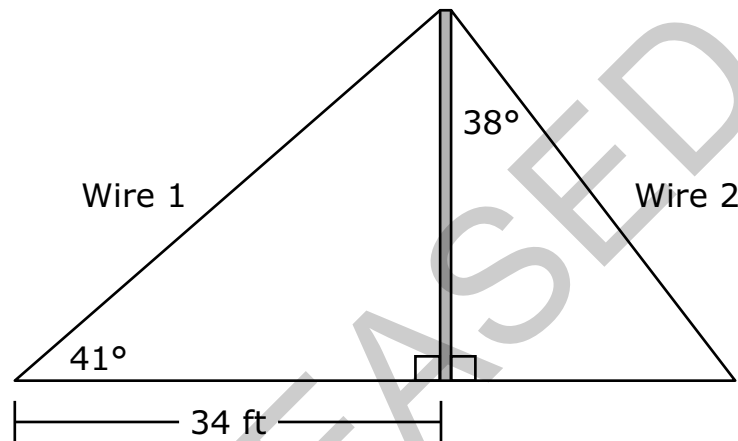

Based on the given information, answer the questions below.

- How tall is the pole?
 - How far from the base of the pole does Wire 2 attach to the ground?
 - How long is Wire 1?
- 2 The amount of time it takes to build a road varies inversely with the number of workers building the road. Suppose it takes 50 workers 8 months to build the road.
- What is the constant of variation?
 - Write an equation that could be used to determine how long it would take n workers to build the road. (Be sure to define the variables.)
 - How much faster would 60 workers build the road than 50 workers?



- 3 The function $f(x)$ is defined as $f(x) = x^2 + 2x - 4$. The function $g(x)$ is defined as $g(x) = -3f(x) + 2$.
- Graph $g(x)$ for $-2 \leq x \leq 2$.
 - Describe the transformations that take the function $f(x)$ onto $g(x)$.
 - Write a new function, $h(x)$, that transforms $g(x)$ back onto $f(x)$.

RELEASED



This is the end of the Common Core Math II test.

- 1. Look back over your answers.**
- 2. Put all of your papers inside your test book and close the test book.**
- 3. Place your calculator on top of the test book.**
- 4. Stay quietly in your seat until your teacher tells you that testing is finished.**

RELEASED



Common Core Math II
RELEASED Form
Spring 2013
Answer Key

Item number	Type	Key	Conceptual Category
1	MC	C	F — Function
2	MC	D	F — Function
3	MC	A	G — Geometry
4	MC	C	S — Statistics and Probability
5	MC	B	S — Statistics and Probability
6	MC	A	A — Algebra
7	MC	B	A — Algebra
8	MC	C	A — Algebra
9	MC	B	A — Algebra
10	MC	A	A — Algebra
11	MC	B	A — Algebra
12	MC	D	A — Algebra
13	MC	C	S — Statistics and Probability
14	MC	D	G — Geometry
15	MC	D	F — Function
16	MC	A	F — Function
17	MC	B	G — Geometry
18	MC	C	G — Geometry
19	MC	A	F — Function
20	MC	D	F — Function
21	MC	C	G — Geometry
22	MC	B	G — Geometry
23	MC	C	A — Algebra

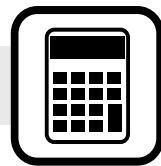

Item number	Type	Key	Conceptual Category
24	MC	B	A — Algebra
25	MC	D	N — Number and Quantity
26	CR	Rubric	G — Geometry
27	CR	Rubric	A — Algebra
28	CR	Rubric	F — Function

Item Types:

MC = multiple choice

CR = constructed response

RELEASED